

BM-11-401

Stainless steel mounting kits, assembled with: BM11

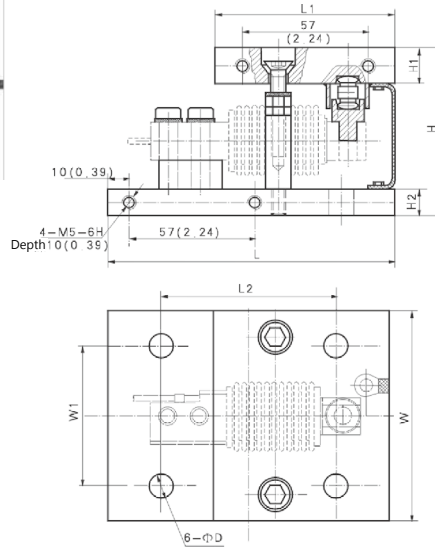
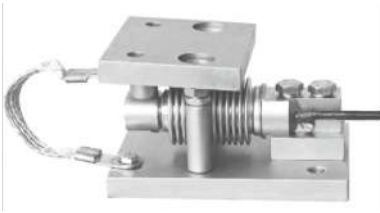

FEATURES

- Compact construction, easy installation
- With anti-reversal ability
- With anti-overloading ability
- With self-aligning ability

Capacity	Part number
5kg-200kg	BM-11-401-5/200kg
250kg-500kg	BM-11-401-250/500kg

Dimension	5kg-200kg	250kg-500kg
Capacity (klb)		
H	77 (3.03)	90 (3.54)
H1	12 (0.47)	20 (0.79)
H2	12 (0.47)	15 (0.59)
L	130 (5.12)	160 (6.3)
L1	75 (2.95)	100 (3.94)
L2	95 (3.74)	100 (3.94)
W	90 (3.54)	120 (4.72)
W1	60 (2.36)	80 (3.15)
ΦD	Φ9 (0.35)	Φ14 (0.55)

BM-11-402

Stainless steel mounting kits, assembled with: BM11

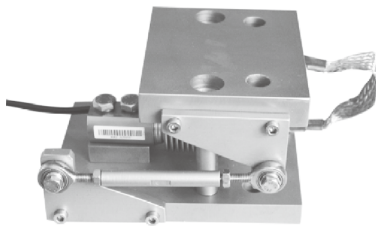

Capacity	Part number
5kg-200kg	BM-11-402-5/200kg
250kg-500kg	BM-11-402-250/500kg

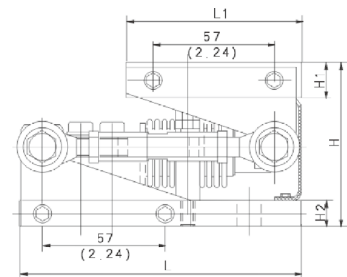

FEATURES

- Compact construction, easy installation
- With anti-reversal ability
- With horizontal locating ability
- With anti-overloading ability
- With self-aligning ability

Dimension	5kg-200kg	250kg-500kg
Capacity (klb)		
H	77 (3.03)	90 (3.54)
H1	12 (0.47)	20 (0.79)
H2	12 (0.47)	15 (0.59)
L	130 (5.12)	160 (6.3)
L1	75 (2.95)	100 (3.94)
L2	95 (3.74)	100 (3.94)
W	90 (3.54)	120 (4.72)
W1	60 (2.36)	80 (3.15)
ΦD	Φ9 (0.35)	Φ14 (0.55)

