

FEATURES

- Stainless steel construction, dual shear beam structure, adhesive sealed, compression loading available.
- Ingress protection (according to EN 60529): IP67
- Suitable for electronic truck scales, hopper scales, track scales and other electronic weighing devices.



AVAILABLE MODELS

Capacity xxklb	Accuracy C3	Full article description B9E-C3-xxK-9B



SPECIFICATION

Maximum capacity (E _{max})	klb	50/60/65/75/100/125/150		
Accuracy class		C3		
Maximum number of load cell intervals (nLC)		3000		
Ratio of minimum LC verification interval Y=E _{max} / V _{min}		10000		
Combined error	%FS	±0.020		
Creep	%FS/30min	±0.016		
Temperature effect on sensitivity	%FS/10°C	±0.011		
Temperature effect on zero	%FS/10°C	±0.015		
Output sensitivity (=FS)	mV/V	3.0±0.003		
Input resistance	Ω	700±7		
Output resistance	Ω	703±4		
Insulation resistance	MΩ	≥ 5000 (50VDC)		
Zero balance	%FS	±1.0		
Compensated temperature	°C	-10~+40		
Operating temperature	°C	-35~+65		
Excitation, recommended voltage	V	5~12 (DC)		
Excitation maximum	V	18 (DC)		
Safe overload	%FS	150		
Ultimate overload	%FS	300		
ATEX classification (optional)		II1G Ex ia IIC T4	II1D Ex iaD20 T73°C	II3G Ex nL II C T4

DIMENSIONS IN MM

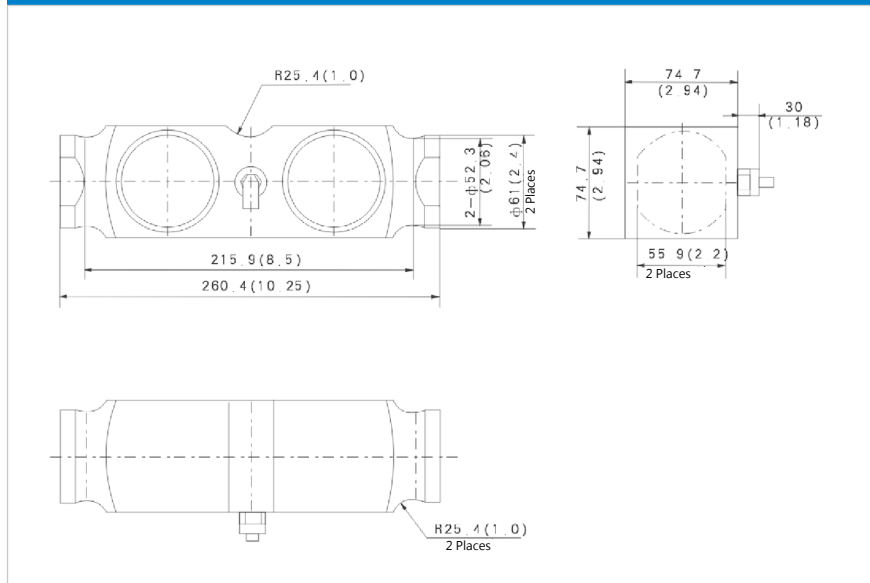

WIRING

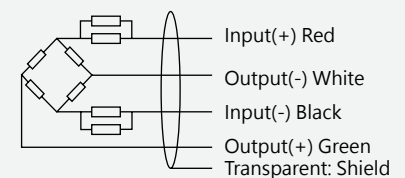

- Adopt shielded, 4 conductor cable: Φ5mm
- Standard cable length: 9m.