

HM-8-402

SHORT DESCRIPTION

- Compact construction, easy installation.
- Adjustable mounting height,
- Using under heavy static load or slight dynamic load.

AVAILABLE MODELS

| Capacity | Capacity |
|------------|-----------------|
| 0.5t-2t | HM-8-402-0.5/2t |
| 2.5t-5t | HM-8-402-2.5/5t |
| 1klb-5KSE | HM-8-402-1/5KSE |
| 5klb-10klb | HM-8-402-5/10K |

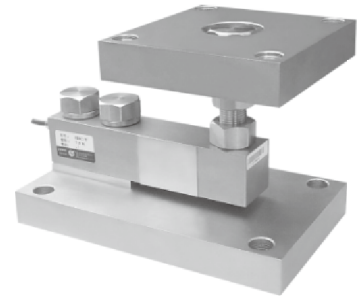

Alloy steel, assembled with: H8C, B8D.

OUTLINE DIMENSION MM(INCH)

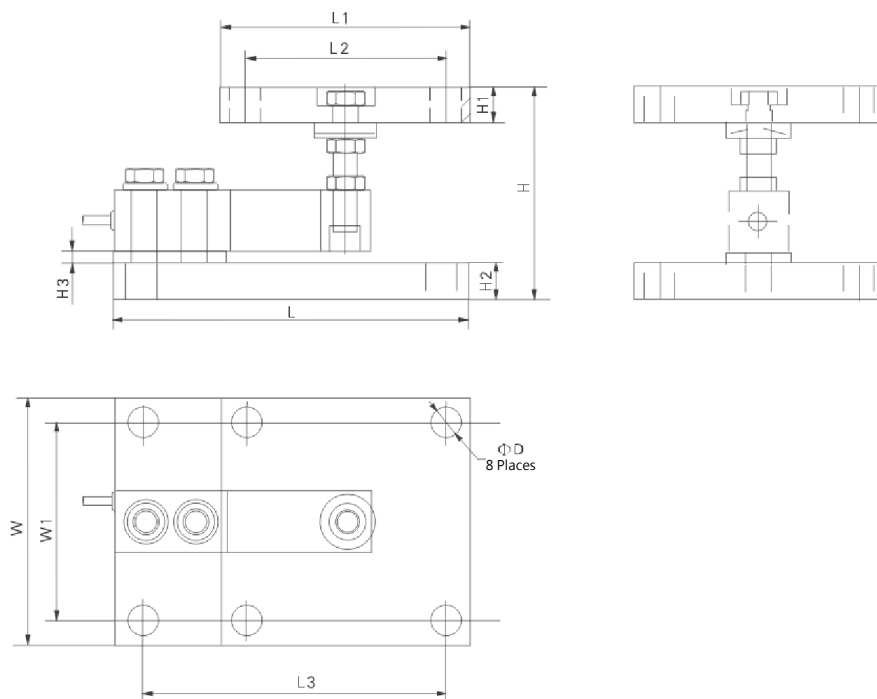

| Dimension Capacity(t) | L | L1 | L2 | L3 | H | H1 | H2 | H3 | W | W1 | D |
|--------------------------|-----------------|--------------|----------------|----------------|------------------------|--------------|--------------|---------------|--------------|----------------|--------------|
| 0.5t-2t (1klb-5KSE) | 180.9 (7.12) | 127 (5.0) | 101.6 (4.0) | 152.4 (6.0) | 100-120 (3.94-4.72) | 18 (0.71) | 18 (0.71) | 4.0 (0.16) | 127 (5.0) | 101.6 (4.0) | 16 (0.63) |
| 2.5t-5t (5klb-10klb) | 215.9 (8.5) | 127 (5.0) | 101.6 (4.0) | 177.8 (7.0) | 130-150 (5.12-5.91) | 26 (1.02) | 26 (1.02) | 4.0 (0.16) | 127 (5.0) | 101.6 (4.0) | 16 (0.63) |